

Septic Sludge Receiver SSR

- Modern construction from robust stainless high quality materials.
- Totally self cleaning. No spraying or brushes.
- Hinged supports enables quick pivoting out of both screen and conveyor for service.
- Enclosed, safe & hygienic with easy to open access doors.

Length 3000-4000mm
Width 1600-2300mm
Bar spacing 3-6mm
Capacity 1-6m³/min

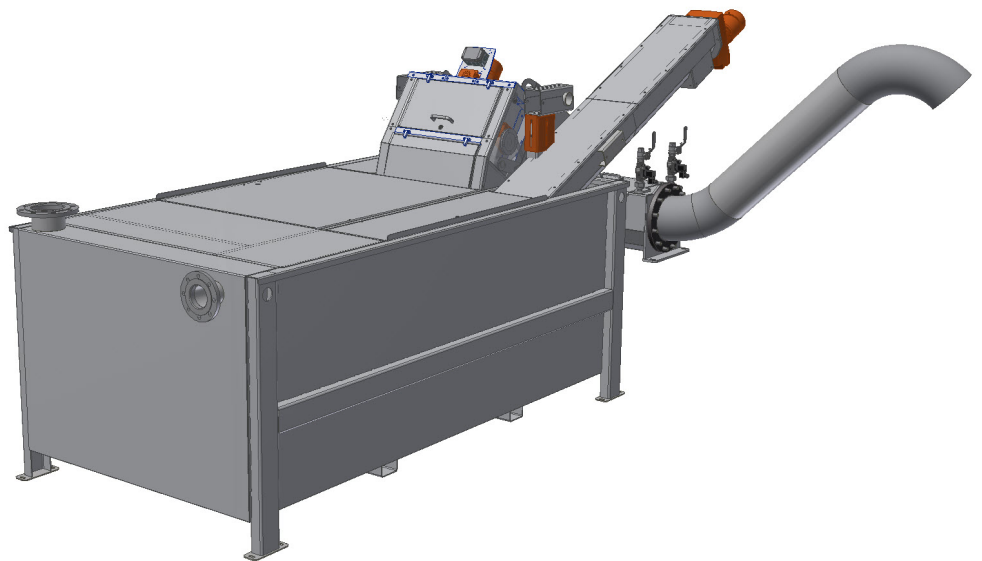

SSR screens septic sludge pumped from tanker trucks or internal sludges at wwtps. It's a non pressurised freestanding easy accessible system. Self cleaning without brushes or flushing. SSR is fully enclosed, well ventilated with compressor tanker air evac. It consists of a tankmounted Andersson Stair Screen ASS with 3-6mm bar spacing and a Wash Press Compactor WPC. SSR can be equipped with integrated stone trap compartment and stone conveyor SSC. From the stone trap the sludge flows over a weir into the screen compartment. The stone trap separates grit and stones to protect the screen, compactor and the following process from wear. The separated screenings debris is treated by the Wash Press Compactor WPC pressing against the friction of a stand pipe or a Back Pressure Shredder BPS.

Andersson Water has hundreds of international references and has worked with machinery within water treatment for over 20 years. We offer the most innovative solutions and the most extensive knowledge on screening equipment. All our products are made acc to ISO & CE standards, We have strong steel working traditions and high quality culture. We only use certified materials and welders.

Andersson Water AB, Ovre Hallegatan 40, 41713, Gothenburg, Sweden, Tel +46761677087
www.anderssonwater.se, Email: info@anderssonwater.se, VAT SE556939595601