

## Grit Separator Classifier GSC

- Modern construction from robust certified stainless high quality materials.
- Compact design with large surface & volume.
- Open clog free inlet & outlet
- Thick wear resistant screw and wear liner.
- Enclosed, safe & hygienic with easy to open access doors.

Capacity 10-30l/s

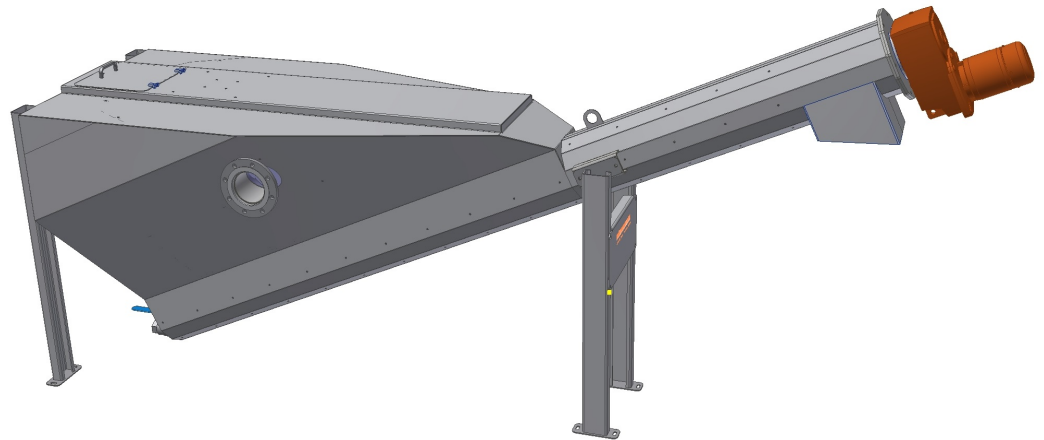

Grit Separator Classifier GSC separates & dewateres sand from water. Street sand, filter sand and similar materials can be handled.

The sand/water mix is pumped or fed into the separation tank where sand settles. After settling the screw conveyor dewateres & conveys the sand. Excess water during pumping flows out over a weir and is led out.

Andersson Water has hundreds of international references and has worked with machinery within water treatment for over 20 years. We offer the most innovative solutions and the most extensive knowledge on screening equipment. All our products are made acc to ISO & CE standards, We have strong steel working traditions and high quality culture. We only use certified materials and welders.